



NovusAer Installation Manual & Owner's Manual



(IMPORTANT – This document is Customer Property and is to remain with this unit.)

© Essential Air Products, LLC



(IMPORTANT – This document is Customer Property and is to remain with this unit.)

Table Of Contents

Performance Data	4
Model Number Nomenclature	4
Product Data	5
Installation Instructions	6
Installation Option A	7
Installation Option B	14
Installation Option C.	21
Installation Option C(a)	26
Installation Option D	27
Installation Option E.	27
Installation Option E(a)	33
Horizontal / Up Air Flow Kit	34
Testing Procedure	36
Limited Warranty	37
Technical Support	38
Owners Manual	39

Performance Data

NovusAer Pressure Drop Table									
	CFM	400	600	800	1,000	1,200	1,400	1,600	1,800
Model									
NS1024-4(8)		.08	.14	.20	.27	.38	NR	NR	NR
NS1224-4(8)		.06	.09	.14	.19	.28	.37	NR	NR
NS1424-4(8)			.05	.09	.14	.18	.28	.35	NR
NS1624-4(8)				.05	.09	.13	.18	.23	.33
NS2024-4(8)					.04	.09	.13	.22	.29

Model Number Nomenclature

1 st Digit	2 nd Digit	3 rd /4 th Digit	5 th /6 th Digit	8 th Digit
N = NovusAer	S = Side	CFM x 100	24 = 24"Dx48"L	4 = 4 Filters
P = PurusAer	H = Horizontal		20 = 20"Dx28"L	8 = 8 Filters

WARNING

This information is for use by individuals having adequate backgrounds of HVAC equipment installation and mechanical experience. Any attempt to install, service or repair an HVAC product such as this may result personal injury and/or property damage. The manufacturer or seller cannot be responsible for the interpretation of this information, nor can it assume any liability in connection with its use.

For information purposes in the following instructions please refer to the diagram bellow:

“Wide End”
of the cabinet

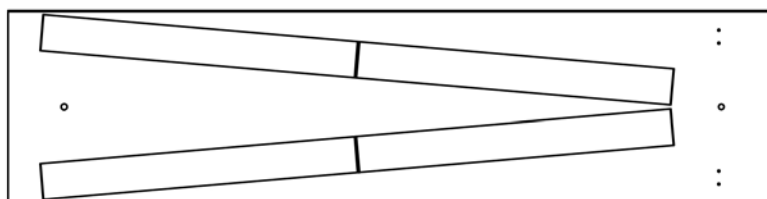

“Apex End”
of the cabinet

NovusAer Product Data

Near HEPA Medical-Grade Residential Air Filtration Unit

Application

The NovusAer Series is a V-bank filter cabinet that connects to the return air duct of a forced air system. This residential filtration unit has been designed to provide the highest possible air cleaning rate at the lowest possible pressure drop for residential forced air systems.

Five models are available:

- Model NS1024 design air flow rate is 1,000 cfm (1,700 m3/h).
- Model NS1224 design air flow rate is 1,200 cfm (2,040 m3/h).
- Model NS1424 design air flow rate is 1,400 cfm (2,380 m3/h).
- Model NS1624 design air flow rate is 1,600 cfm (2,720 m3/h).
- Model NS2024 design air flow rate is 2,000 cfm (3,400 m3/h).

Lower and higher airflows are permissible. The lower the air flow the lower the pressure drop will be. The higher the air flow, the higher the pressure drop will be. We do not recommend higher than .36" WC pressure drop. As the pressure drop increases, the HVAC system's energy efficiency and capacity decreases.

Features

- Near HEPA efficiency – MERV16+, Catches 100% of PM2.5 particles
- Low air flow resistance
- Longer filter life: 3 years in average home use
- Fits where other filters can't
- Up Flow, Down Flow, Horizontal Right or Left
- Quick and easy filter replacement: No tools needed
- Heavy Duty 22 ga steel cabinet
- Medical grade finish: Powder coated galvanized steel
- 10-year Cabinet and Hardware warranty
- 20-year Clean Coil guarantee

Unit Dimensions

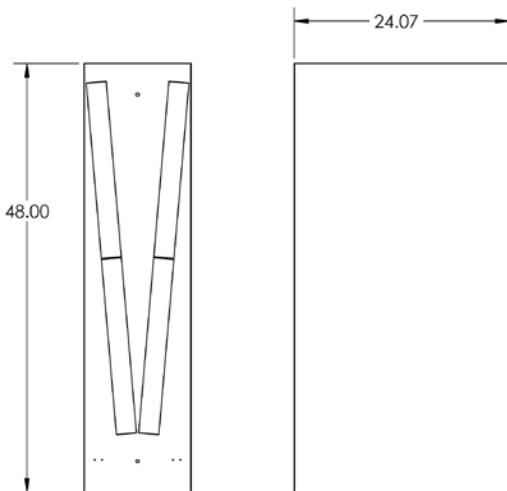

Model	Height	Width A	Depth
NS1024-4(8)	48"	10"	24"
NS1224-4(8)	48"	12"	24"
NS1424-4(8)	48"	14"	24"
NS1624-4(8)	48"	12"	24"
NS2024-4(8)	48"	18"	24"

Provide a minimum of 24" of service clearance in front of -4 models and 12" in front of -8 models

Installation Instructions

The NovusAer S-Series can be floor-mounted, mounted to the side or bottom/inlet of a furnace/air handler or suspended from exposed ceiling joists or the ceiling surface. (see pages 6 -32 for installation option examples).

Choose a location between the return air plenum duct and the furnace/air handler which is readily accessible for checking and replacing the filters. Allow at least 19.5” (49.5 cm) clearance in front of the -4 models and 11.75” (29.5 cm) clearance in front of the -8 models.

Remove the air filters, access door, access door hardware and air filter gauge from the inside of the unit. **CAUTION: When reinstalling the air filters, they must be installed so that the air flow arrows are pointing in the direction of the air flow through the cabinet.**

Always follow the air handler/furnace equipment manufacturers instructions for the number of return air openings required.

This air filter must be mounted in the return air duct of a central forced-air furnace or air handler. Do NOT install the NovusAer filter cabinet in the discharge air stream of a furnace or air handler.

All phases of the installation of this product must comply with NATIONAL, STATE AND LOCAL CODES.

Note: In order that the air filter cabinet access is not blocked, there may be gas line connections, electrical service connections, low voltage control wire connections, venting connections and/or condensate drainpipe connections that will need to be relocated or rerouted.



CAUTION

SAFETY HAZARD

Sharp edge hazard. Be careful of sharp edges on equipment or any cuts made on sheet metal surfaces while installing or servicing the NovusAer cabinet. Personal injury may result.



CAUTION

Do NOT install this air filter cabinet where the air filters will be exposed to UV light. UV light can cause the air filter material to deteriorate, which may lead to air filter damage.

Installation Option A:

The cabinet can be directly mounted to the side of the furnace/air handler as shown in Figure 1A. The air flow will enter the wide end at the “top” of the filter assembly and exit the apex end at the “bottom” of the filter assembly.)

Figure 1A.



This is done by installing the end cap (included) on the filter assembly apex end (“bottom”) of the cabinet. Next, cut an opening to match the opening in the furnace/air handler in the right or the left side of the cabinet as needed staying within 2” from the apex end (“bottom”) of the cabi-

net. This opening is now the cabinet outlet. Before attaching the cabinet to the furnace/air handler, use mastic or silicone to seal all inside seams and corners of the end cap to be airtight. Next, using standard SMAC-NA duct installation practices, attach and seal the cabinet to the furnace/air handler. The cabinet inlet (the remaining open “top” end) can now be connected to the main return air plenum. Most of the time, a transition duct connection will be required. Use standard duct installation practices to make this transition. Finish the installation by installing the air filters and filters, access door hardware, access door and air filter gauge. See steps 1 through 12 and figures 1B – 1M for step-by-step examples.

Figure 1B. Typical “Option A” example.



Step 1. (See Figure 1C.) Remove enough of the return air plenum duct to allow room for the new filter cabinet, and duct transition.

Figure 1C. Remove return air duct.



Step 2. (See Figure 1D.) Staying within 2” from the bottom of the filter cabinet, cut an opening in the side of the filter cabinet to match the opening in the furnace or air handler. Install the filter cabinet door hardware on the front of the cabinet.

Figure 1D. Cut opening in the side of the cabinet

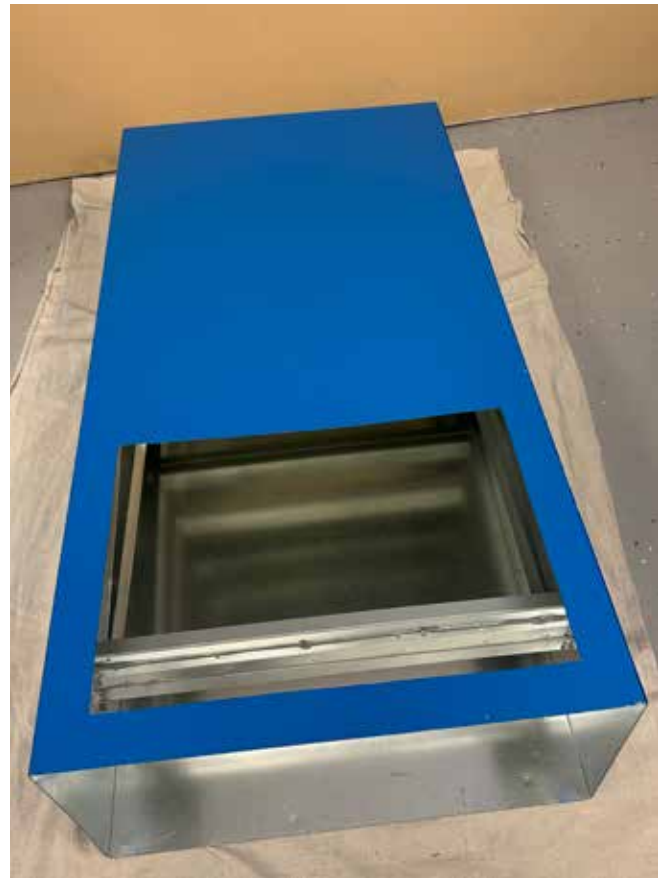

Step 3. (See Figure 1E.) Using the end cap and s-cleats included with the unit, install the end cap on the bottom side of the cabinet. Secure the end cap to the filter cabinet.

Figure 1E. Install the end cap on the bottom.



Step 4. (See Figure 1F.) Using SMACNA approved practices, seal the end cap connections to the filter cabinet.

Figure 1F. Seal the end cap.

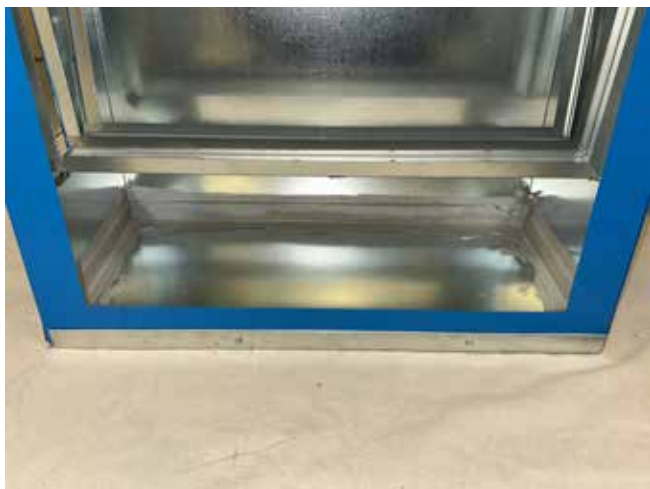

Step 5. (See Figures 1G1, 1G2, 1G3.) Install the door mounting hardware and air filter gauge onto the front of the cabinet.

Figure 1G1. Install the door mounting hardware.



Figure 1G2. Install the door latch hardware.



Figure 1G3. Install the air filter gauge.



Step 6. (See Figures 1H1, 1H2, 1H3.) Using SMACNA approved practices, secure and seal the cabinet to the furnace or air handler. To air seal the connection to prevent air from being drawn into the return air connections, we recommend that an approved sealant be applied as a gasket between the filter cabinet and the furnace or air handler.

Figure 1H1. Install the cabinet on the furnace/air handler.



Figure 1H2. Seal the connection with s-cleats.



(Furnace blower compartment with blower removed to give photo access.)

Figure 1H3. Seal the connection with tape.



(Furnace blower compartment with blower removed to give photo access.)

Step 7. (See Figure 1J.) Using SMACNA approved practices, install and seal a duct transition between the filter cabinet and the return air plenum duct.

Figure 1J. Install the transition



Step 9. (See Figure 1K.) Install the air filters into the filter cabinet with the handles facing out.

Figure 1K. Install the filters.



Step 10. (See Figure 1L.) Install the filter cabinet door.

Figure 1L. Install the door.



Step 11. (See Figure 1M.) Follow the manufacturer's instructions to set up the air filter gauge.

Figure 1M. Set up the filter gauge.



Step 12. Test the air filter as per the recommended testing procedures in this instruction manual.

Installation Option B:

The cabinet can be mounted on a return plenum extension box (duct with end cap) as shown in figure 2A. As in “Option A” above, the air flow will enter the wide end of the filter cabinet and exit the apex end of the filter cabinet.

Figure 2A.



To mitigate filter access obstructions such as gas lines, electrical connections, condensate lines, and venting connections, it may be necessary to mount the cabinet on a short section of duct. This is done by making a “box” by installing the end cap (included) onto a section of duct (not in-

cluded) that matches the width (10”, 12”, 14”, 16” or 18”) and depth (24”) of the cabinet. The length of the duct is determined by the length needed to clear the obstructions. Typically, 18” is sufficient. Next, seal the inside of the end cap seams and corners with mastic or silicone. Then cut an opening in the side of the box to match the opening in the furnace/air handler. Next, using standard SMACNA duct installation practices, attach and seal the box to the furnace/air handler. Then attach the cabinet to the open end of the box using the same standard practices. The cabinet inlet can now be connected to the main return air plenum. Most of the time, a transition duct connection will be required. Use standard duct installation practices to make this transition. Finish the installation by installing the air filters, access door hardware, access door and air filter gauge. See steps 1 through 13 and figures 2B – 2P for step-by-step examples.

Figure 2B. Typical “Option B” Example.



Step 1. (See Figure 2C.) Remove enough of the return air plenum duct to allow room for the new filter cabinet, plenum extension box, and duct transition.

Figure 2C. Remove return air duct.



Step 2. (See Figure 2D.) Make a plenum extension box the same width and depth as the filter cabinet to be installed. Do this by installing an end cap on the bottom of a duct that is the height needed to raise the filter cabinet above the obstacles to be avoided. An 18” high extension is very common.

Figure 2D. Build extension box.



Step 3. (See Figure 2E.) Cut an opening in the side of the plenum extension box to match the return air opening in the furnace or air handler.

Figure 2E. Cut opening in the side of the box



Step 4. (See Figure 2F.) Using SMACNA approved practices to seal the end cap to the duct and seal the seams.

Figure 2F. Seal the extension box.



Step 5. (See Figure 2G.) Install the door mounting hardware onto the front of the cabinet.

Figure 2G. Install door mounting hardware



Step 6. (See Figure 2H.) Install the door latch hardware onto the front panel of the cabinet.

Figure 2H. Install door latch hardware



Step 7. (See Figure 2J.) Install filter gauge on the front panel of the cabinet.

Figure 2J. Install filter gauge



Step 8. (See Figure 2k.) Install the plenum extension box on the bottom of the cabinet. Using SMACNA approved practices, seal the plenum extension duct to the cabinet. We recommend you apply an approved sealant as a gasket between the plenum extension box and the furnace or air handler.

Figure 2K. Install and seal extension box.



Step 9. (See Figures 2L.) Using SMAC-NA approved practices, secure and seal the cabinet and plenum extension assembly to the furnace or air handler.

Figure 2L. Install cabinet assembly on furnace/air handler.



Step 10. (See Figure 2M.) Using SMAC-NA approved practices, install and seal a duct transition between the filter cabinet and the return air plenum duct.

Figure 2 M. Install and seal duct transition.



Step 11. (See Figure 2N.) Install the air filters into the filter cabinet with the handles facing out.

Figure 2N. Install air filters.



Step 12. (See Figure 2P.) Install the filter cabinet door. Follow the manufacturer's instructions to set the filter gauge up.

Figure 2P. Install filter door



Step 13. Test the air filter as per the recommended testing procedures in this instruction manual.

Installation Option C:

The Cabinet can be mounted in a “counter flow” furnace/air handler configuration as shown in figure 3A. The air flow will enter the apex end of the filter cabinet and exit the wide end of the filter cabinet.

Figure 3A. Typical “Option C” installation.



This is done by installing the cabinet into the return air plenum using standard SMACNA duct installation practices. Most of the time, two transition duct connections will be required. Use standard duct installation practices to make this transition. Finish the installation by installing

the air filters, access door hardware, access door and air filter gauge. See steps 1 – 10, and figures 3B – 3L for step-by-step examples

Figure 3B. Typical “Option C” Example



Step 1. (See Figure 3C.) Remove enough of the return air plenum duct to allow room for the new filter cabinet and two duct transition connections.

Figure 3C. Remove a section of return air duct.



Step 2. (See Figure 3D.) Using SMACNA approved practices, install and seal a duct transition to the lower return air duct.

Figure 3D. Install the transition



Step 3. (See Figure 3E.) Install the door mounting hardware onto the front panel of the filter cabinet.

Figure 3E. Install door mounting hardware.



Step 4. (See figure 3F.) Install the door latching hardware onto the front panel of the cabinet.

Figure 3F. Install door latching hardware.



Step 5. (See Figure 3G.) Using SMACNA approved installation practices, install and seal the filter cabinet to the transition duct.

Figure 3G. Install filter cabinet.



Step 6. (See Figure 3H.) Using SMACNA approved installation practices, install and seal a transition duct between the top of the filter cabinet and the upper return air plenum duct.

Figure 3H. Install and seal upper transition duct.



Step 7. (See Figure 3J.) Install the air filters into the filter cabinet with the handles facing out.

A “Horizontal / Up Air Flow Kit” (Pages 34-35) is required in this Option configuration.

Figure 3J. Install the air filters



Step 8. (See Figure 3K.) Install the filter cabinet door. Drill a 5/16” hole in the duct approximately 4” above the transition duct, centered in the duct.

Figure 3K. Install filter cabinet door.



Figure 3L. Install filter gauge in the duct above



Step 10. Test the air filter as per the recommended testing procedures in this instruction manual.

Step 9. (See Figure 3L.) Install the air filter gauge on the duct above the filter cabinet. Seal the factory provided filter gauge hole in the front panel of the filter cabinet with approved tape or sealant. Follow the manufacturer's instructions to set up the air filter gauge.

Installation Option C(a):

The cabinet can be directly mounted to the side of the furnace/air handler in a counter flow configuration as shown in Figure 4A. However, the door will be upside down. (The air flow will enter the wide end of the filter cabinet and exit out the apex end of the filter cabinet.) This is done by installing the end cap (included) on the filter assembly apex end of the cabinet. Next, cut an opening to match the opening in the furnace/air handler in the right or the left side of the cabinet as needed staying within 2” from the apex end of the cabinet. This opening is now the cabinet outlet. Before attaching the cabinet to the furnace/air handler, use mastic or silicone to seal all inside seams and corners of the end cap to be airtight. Next, using standard SMAC-NA duct installation practices, attach and seal the cabinet to the furnace/air handler. The cabinet inlet (the remaining open end) can now be connected to the main return air plenum. Most of the time, a transition duct connection will be required. Use standard duct installation practices to make this transition. Finish the installation by installing the air filters, access door hardware, access door and air filter gauge.

A “Horizontal / Up Air Flow Kit” (Pages 34-35) is required in this Option configuration.

Caution: Option C(a) type of installation can have an abnormally high pressure drop. We recommend this type of installation be done if it is the only option type available.

Figure 4A



Installation Option D:

The cabinet can be mounted in a horizontal position in the furnace/air handler return plenum as shown in figure 5A. The cabinet can be mounted in either horizontal left or horizontal right position with the filter assembly wide end facing toward the furnace/air handler. This is done by installing the cabinet between the furnace and the return air plenum using standard SMACNA duct installation practices. Most of the time, two transition duct connections will be required. Use standard duct installation practices to make this transition. Finish the installation by installing the air filters, access door hardware, access door and air filter gauge.

A “Horizontal / Up Air Flow Kit” (Pages 34-35) is required in this Option configuration.

Figure 5A



Installation Option E:

The cabinet can be mounted in a side and bottom combination configuration as shown in figure 6A. The air flow will enter the wide end of the filter assembly and exit out the apex end of the filter assembly.

Figure 6A



This is done by installing the cabinet into the return air plenum using standard SMACNA duct installation practices. Most of the time, two transition duct connections will be required. Use standard duct installation practices to make this transition. Finish the installation by installing

the air filters, access door hardware, access door and air filter gauge. See steps 1 - 12, figures 3B - 3L for step-by-step examples

Figure 6B Typical Intallation



Step 1. (See Figure 6C.) Build or use a commercially made furnace base. Seal the inside seams.

Figure 6C. Build/use a Prefab furnace base. Seal the base.



Step 2. (See Figures 6D1, 6D2.) Put approved sealant or gasket material on the surfaces of the base that connect with the furnace/air handler.

Figure 6D1. Put sealant on connecting surfaces.



Figure 6D2. Put sealant on connecting surfaces.



Step 3. (See Figure 6E.) Remove enough of the return air plenum duct to allow room for the new filter cabinet, furnace base and duct transition. Install the furnace/air handler on top of the base.

Figure 6E. Remove duct. Set the Furnace on the base.



Step 4. (See Figure 6F.) Remove the endcap. Install the filter door hardware onto the NovusAer filter cabinet.

Figure 6F. Install door mounting hardware.



Step 5. (See figure 6G.) Remove the endcap. Install the door latch hardware on the front panel of the cabinet.

Figure 6G. Install door latch hardware.



Step 6. (See Figure 6H.) Staying within 2” from the bottom apex end of the filter cabinet, cut an opening in the side of the filter cabinet to match the opening in the furnace/air handler.

Figure 6H. Cut an opening in the side to match the furnace.



Step 7. (See figure 6J.) Install the air filter gauge on the front panel of the filter cabinet.

Figure 6J. Install filter gauge.



Step 8. (See Figure 6K.) Install and seal the NovusAer cabinet onto the base. Using SMACNA authorized practices, seal the cabinet opening to the furnace.

Figure 6K. Install and seal the cabinet to the base and the furnace.



Step 9. (See Figure 6L.) Using SMACNA approved installation practices, install and seal a transition duct between the top of the filter cabinet and the upper return air plenum duct.

Figure 6L. Install upper transition.



Step 10. Figure 6M. Install the air filters into the filter cabinet with the handles facing out

Figure 6M. Install air filters.



Step 11. (See Figure 6N.) Install the filter cabinet door onto the filter cabinet.

Figure 6N. Install cabinet door.



Step 12. Using the air filter gauge manufacturer's set up instructions, set up the air filter gauge.

Step 13. Test the air filter as per the recommended testing procedures in this instruction manual.

Installation Option E(a):

The cabinet can be installed in the Option E configuration while adding the Option B duct box extension to the base leaving the bottom of the extension duct open as shown in figures 7A. Otherwise follow the instructions for Option E above. This option can be installed in a bottom inlet only or a side and bottom configuration.

Figure 7A



Horizontal / Up Air Flow Kit

To prevent air from bypassing around the air filters inside the filter racks, when installed in Option A, B, E and Ea configurations, both gravity and air flow push the air filter gaskets against the surface of the filter racks to create an airtight seal. However, when the units are installed in the Optional C, Ca, and D configurations, to create an airtight gasket seal, a Horizontal / Up Air Flow Kit is required. Install the Kit as per the instructions below:

Step 1. Procure the 3/8" window gasket material from your local home improvement store as shown below:



Step 1 Figure 1.



Step 1 Figure 2.

Step 2. Place the air filters on a clean flat surface with the gasketed side facing down as shown below:

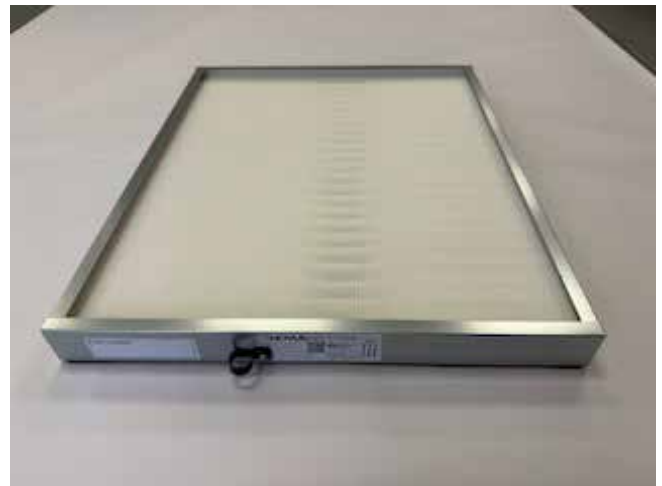

Step 2

Step 3. Install strips of the gasket material along both long sides of the air filters as shown below:



Step 3

Step 4. Install the air filters into the air filter cabinets as you normally would in each optional configuration. See the example of a horizontal, Option D configuration below:



Step 4 Figure 1



Step 4 Figure 2



Step 4 Figure 3

Testing Procedure

To ensure that the NovusAer air filtration system is delivering “20X Cleaner Air”, follow these test procedure steps:

The test must be done with the home not having filtered air. After all, how can you prove that the air filter is working if the air going into it is already clean?

Either do this test immediately after the filter cabinet has been completely installed and has not yet operated (recommended) or:

Remove the NovusAer air filters out of the cabinet and let the air circulate until the space has had at least one air change. The time to achieve one air change will vary with the air tightness of the home. As examples: One air change can take as little as 1 hour in an average constructed home; 3 hours for an Energy Star Certified home; or as long as 12 hours for a Passive House Certified home. One air change has been achieved when the particle count inside the home is the same or higher than the particle counts outside the conditioned space.

If they have not been removed already, based on 1a or 1b above, remove the NovusAer air filters from the cabinet. (Re)Install and secure the filter cabinet door.

Unless one already exists, create an air sampling hole in the duct upstream of the NovusAer cabinet (preferred method). If necessary, the sampling hole can be placed in the NovusAer cabinet within one inch from either end of the cabinet (acceptable method).

To simulate normal air cleaning operations, turn the HVAC system to the off mode and place the HVAC system into the air circulation (fan only) mode.

Using an NIST approved laser particle

counter, insert the probe into the sampling hole and collect a sample of the incoming air.

Record the number of PM2.5 particles in the incoming air sample. (typical scale range 1.0 to 3.0 microns)

Using the same laser particle counter used in the incoming air sampling, take an air sample of the air leaving the NovusAer cabinet by:

Inserting the laser particle counter sampling probe into a supply air vent in the system being tested (referred method). Make sure only air from the system can be collected into the probe or:

Unless one already exists, you can create an air sampling hole in the duct downstream of the NovusAer cabinet and take a sample there (acceptable method). If necessary, the sampling hole can be placed in the NovusAer cabinet within one inch from either end of the cabinet (acceptable method).

Record the number of PM2.5 particles in the outgoing air sample. (typical scale range 1.0 to 3.0 microns)

Use the following formula to calculate the efficiency of the air filtration system:

$$1 - (\text{outgoing air} \div \text{incoming air}) \times 100 = \% \text{ efficiency.}$$

$$\text{Example 1} - (5,000 \text{ particles} \div 100,000 \text{ particles}) \times 100 = 95\%$$

Or use the following formula to calculate NUMBER X cleanliness of the air:

$$100 / (\text{outgoing air} \div \text{incoming air}) = \text{NUMBER X}$$

$$\text{Example: } 100 \div (5,000 \text{ particles} \div 100,000 \text{ particles}) = 20\text{X cleaner}$$

NovusAer Limited Warranty

10 (Ten) Year Parts Limited Warranty

Essential Air Products, llc covers the NovusAer air cleaning system with a ten (10) year limited warranty to the original owner. If within 10 years from the original date of purchase by the end-user from an authorized NovusAer Dealer/Installer this cabinet assembly or any part thereof, except for the air filters, is found to be defective by reason of faulty workmanship or materials, Essential Air Products, llc will at their option replace the faulty cabinet assembly or part free of charge. A defective product will be replaced pursuant to this Limited Warranty with a new Essential Air Products, llc product of equal or similar features and functionality if the original product has been discontinued or is no longer available. This warranty is for parts only and does not include labor. The warranty for replaced cabinet assembly or parts will automatically expire with the termination of the original device's warranty.

The following exclusions are not limited to this warranty.

This warranty shall not apply to damage or failure caused by:

- Misuse, normal wear and tear, neglect, unauthorized repair, damage caused by installation, adaptation, modification or use in an improper manner or inconsistent with the NovusAer's installation, operating and maintenance instructions
- Operation of the NovusAer during construction or remodeling.
- Wear or deterioration resulting from environmental conditions or to damage sustained during shipping, handling or transit.
- Essential Air Products, llc will not be liable under this warranty for any fault or damage arising from defective workmanship.
- Essential Air Products will not re-

fund or pay for freight, shipping, handling or insurance costs for warranty repairs.

- Cosmetic damage or normal wear and tear, including, but not limited to: scratches, peeling finish, or dents that do not impede the mechanical functionality of the product.
- Damage caused by acts of nature, including but not limited to: fire, collision, flood, wind, power surge, lighting strike, or mold.

Limit of Liability: IMPLIED WARRANTIES OF MERCHANTABILITY OR FITNESS FOR A PARTICULAR PURPOSE SHALL BE LIMITED IN DURATION TO THE AFOREMENTIONED EXPRESS WARRANTY PERIOD. ESSENTIAL AIR PRODUCTS, LLC LIABILITY FOR INCIDENTAL OR CONSEQUENTIAL DAMAGES, OTHER THAN DAMAGES FOR PERSONAL INJURIES, RESULTING FROM ANY BREACH OF THE AFOREMENTIONED IMPLIED WARRANTIES OR THE ABOVE LIMITED WARRANTY IS EXPRESSLY EXCLUDED. THIS LIMITED WARRANTY IS VOID IF DEFECT(S) RESULT(S) FROM FAILURE TO INSTALL THE PRODUCT ACCORDING TO THE NOVUSAER INSTALLATION INSTRUCTIONS. IF THE LIMITED WARRANTY IS VOID DUE TO MISAPPLICATION OR IMPROPER INSTALLATION, ALL DISCLAIMERS OF IMPLIED WARRANTIES SHALL BE EFFECTIVE UPON INSTALLATION.

Some states do not allow limitations on how long an implied warranty lasts or the exclusion or limitation of incidental or consequential damages, so the above limitation(s) may not apply to your situation. This Limited Warranty gives you specific legal rights, and you may also have other rights which vary from state to state.

Obvious defects must be reported to an authorized NovusAer Dealer/Installer within 90 days of the purchase date.



CAUTION

Do NOT operate the NovusAer air filtration system during construction or remodeling of a home. This unit is designed for use in normal living conditions to capture small particles. The volume dust and condensate in the presence of chlorides and fluorides from paint, varnishes, stains, adhesives, cleaning compounds, and cement creates a corrosive condition which may cause rapid deterioration of the cabinet and components of the NovusAer air filtration unit and the furnace or air handler.

NovusAer Technical Support

Essential Air Products - Technical Support Team

Should technical support be needed before, during or after the installation, please contact the Essential Air Products technical support team at:

Essential Air Products Support
71 N Cutler Dr. STE 6
North Salt Lake, UT 84054
Phone: (+1) 385-399-9682
e-mail: support@essentialairproducts.com

Should a warranty claim need to be submitted, to expedite the process, please have the following information ready when contacting us:

- Product model number
- Product serial number
- Customer/end username, address, phone, e-mail)
- Date of purchase
- Description of problem

- Digital photos of the defect, including the area surrounding defect.
- Dealers name and address

At the sole discretion of Essential Air Products, llc, you may be required to: return the product not later than thirty (30) days after the warranty period to the place of purchase or if directed to Essential Air Products, llc, contact a professional contractor to provide warranty service, submit a product for testing related to a warranty claim, and/or send pictures of the original product with the serial number to Essential Air Products, llc Technical Support for inspection as a condition to reviewing a claim and/or receiving a replacement product under this Limited Warranty.

Thank you for choosing NovusAer made by Essential Air Products!

Owner's Manual

When you choose a genuine NovusAer Whole-House Air Cleaner, you're choosing clean air. Your air cleaner is specifically engineered to work with your NovusAer Air Filters to remove harmful particulates from your home's air such as mold, pet dander, airborne viruses, pollen, PM2.5 particles, and bacteria. Your genuine NovusAer Air Filters are designed for a gasket sealed fit inside your NovusAer Air Cleaner. Delivering clean air to your entire home has never been easier!

Not only do our air filters ensure clean air to breathe, but they also protect your heating and cooling equipment against dirt and dust buildup which can reduce heating, cooling and air cleaning performance.

20-YEAR CLEAN COIL GUARANTEE

If you purchase and have your new NovusAer Air Filtration System installed by a qualified contractor and maintain it according to the manufacturer recommended maintenance instructions, Essential Air Products guarantees that if your indoor coil requires cleaning within the next 20 years, we will pay 75% of the cost (up to \$400) to have it professionally cleaned by a qualified contractor*.

**Installation with a heat pump, air conditioner or high efficiency furnace that is: either brand new, (less than one year old) or if it is more than one year old, with the indoor coil professionally cleaned and restored to near factory conditions by a qualified contractor prior to installation. Proof of Purchase of genuine NovusAer Air Filters, once every three years, required*

Please take a few minutes to read this manual and familiarize yourself with the required product routine maintenance.

OPERATION:

A NovusAer Whole-House Air Cleaner is installed by your contractor as one of the components in your heating, ventilation, and air conditioning (HVAC) system to clean the air that circulates through your home.

When the HVAC equipment turns on, the air in your home travels through the return air grilles and return air ducts to the HVAC equipment where it is conditioned, cleaned and sent back into the rooms of your house through the supply air ducts and registers. Removing air borne particles keeps the HVAC equipment components clean and, more importantly, helps ensure clean air throughout your entire home.

Continuous air cleaning with your NovusAer Whole-House Air Cleaner will be accomplished when your thermostat is set for continuous air circulation ("Fan On"). If continuous air cleaning is not required, or desired, set your thermostat to "Fan Auto".

REQUIRED ROUTINE MAINTENANCE:

Regular replacement of the filter is required to keeping your HVAC system clean and preventing damage caused by particulate buildup. For effective whole-home air purification, your NovusAer Air Cleaner requires genuine NovusAer Replacement Filters.

Essential Air Products recommends replacing your filters every 3 years. Your contractor may recommend more frequent or less frequent filter replacements depending on the HVAC system operation time and the amount of people and pets in the home and their activities. The size

of the home, amount of carpet, number of pets or smokers, and pollution level in your area, the air tightness of your home, all may contribute to your maintenance schedule.

Process to change the genuine NovusAer Air Filters:

1. Remove the filter access door latch knob by turning the knob counter-clockwise until the knob comes off the latching bolt.
2. Remove the filter access door from off of the door mounting hardware.
3. Remove one air filter by pulling the filter by the handle out of the filter slot. Discard the used air filter. Keep the air filter tray.
4. Insert a new air filter into the empty filter slot with the handle facing out. While holding them together, insert them both fully into the empty filter slot. Make sure that the air flow arrows on the air filter sticker are pointing in the direction of the air flow through the air cleaner.
5. Repeat steps 3 and 4 until all four air filters have been replaced.
6. Install the air filter access door back onto the door mounting hardware.
7. Install the access door latching knob onto the door latch bolt. Turn the knob clockwise until the door gasket has sealed against the air filter cabinet.



ESSENTIAL AIR PRODUCTS

Congratulations!
The air coming out of your ducts is 20 times cleaner
than the air going in.

Customer Name:		
Address:		
City:	State:	Zip:
Technician:	Date:	
NovusAer Model Installed:	Serial Number:	

Congratulations on your purchase of a NovusAer air filtration system! You now own one of the most advanced air cleaners in the world, delivering the highest and most consistent Clean Air Delivery Rate (CADR) available.

As a heating contractor with over 47 years of experience, I've seen countless air cleaners come and go. Many made impressive claims but ultimately fell short of delivering the clean air homeowners deserve. When I started using a laser particle counter to test these products, I discovered that most either didn't perform as promised, couldn't clean the air thoroughly, or were impractical for typical homes.

In 2017, I decided to change that. I designed and built the NovusAer air filter to address these shortcomings and provide truly effective air filtration. My hometown of Salt Lake City, Utah, provided the perfect testing ground. Our unique "temperature inversions" trap air pollution in the valley, often giving us some of the worst air quality in the nation.

Over the course of two years, I installed and tested the NovusAer in real homes, refining and perfecting the design. The results were clear: this was a game-changing air cleaner. Confident in its performance, I applied for and was awarded a U.S. patent.

To ensure you can trust NovusAer's performance, I sent it to Blue Heaven Technologies, an independent laboratory in Louisville, Kentucky, for testing in 2023. The results exceeded even my own expectations.

Thank you for choosing the NovusAer air cleaner for your home. I'm confident you'll enjoy the difference it makes, delivering clean, medical-grade air through your heating and cooling system.

Dan Dearden
Inventor and Founder, Essential Air Products llc

Thank you!

We deeply value the trust you've placed in Essential Air Products to provide clean air for you and your family. As a family-owned company, this trust means the world to us. Our dedicated team works tirelessly to deliver the highest-quality air cleaning products and support. Whether you've chosen to enhance your home's air quality to address allergies, asthma, or upper respiratory issues, or simply to protect your loved ones from harmful pollutants like PM2.5 particles, Essential Air Products is committed to safeguarding your family's health.

To honor that commitment, we test and certify the effectiveness of your new NovusAer whole-home air filtration system upon installation. This certification includes testing data documenting that the air delivered through your heating and air conditioning system is now 20 times cleaner. In fact, over 95% of harmful airborne pollutants, including PM2.5 particles (such as bacteria and viruses), are removed by the NovusAer system.

From our family to yours, we wish you the very best in health and well-being.

Air Quality Testing Procedure

1. A handheld laser particle counter that can detect harmful air borne particles down to the size of bacteria and viruses (\geq PM2.5) is used to analyze the air in your home. Such an instrument is commonly used to verify the cleanliness of cleanrooms and hospital operating rooms. After the NovusAer filter housing and access door are installed, but before the air filters are inserted, an INTAKE AIR particle measurement is taken. The heating and cooling system fan is turned on and air is drawn into the intake ducts, commonly known as the return air duct, from all around your home. The laser particle counter sampling tube is inserted into return air duct just prior to entering the NovusAer air filter housing. An INTAKE AIR particle count sample is taken and recorded. The access door is removed and NovusAer air filters are then inserted into the filter housing. The access door is reinstalled. The laser

particle counter sampling tube is inserted into the OUTLET AIR duct, commonly known as the supply air duct, just after leaving the heating and cooling equipment. An OUTLET AIR particle count sample is taken and recorded.

2. The air quality improvement is calculated with the following formula:

$$1 \div (\text{OUTLET AIR particle count} \div \text{INTAKE AIR particle count}) = \text{_____} \\ \text{X Cleaner air}$$

Example: $1 \div (5,000 \div 100,000) = 20\text{X}$ Cleaner air

3. Essential Air Products guarantees that an improvement of at least 95% or better is achieved with the system installed. This means that your supply air is certified to be 20 times cleaner after the installation of the NovusAer air filtration system.

You can also use the following formula to calculate the efficiency of the air filtration system:

$$(1 - (\text{OUTLET AIR particle count} \div \text{INTAKE AIR particle count})) \times 100 = \% \text{ efficiency.}$$

Example $(1 - (5,000 \text{ particles} \div 100,000 \text{ particles})) \times 100 = 95\%$

Air Quality Testing Results

$$1 \div \left(\frac{\text{OUTLET AIR Particle count}}{\text{INTAKE AIR particle count}} \right) = \text{_____} \text{ X Cleaner Air}$$



71 N Cutler Dr. STE 6 • North Salt Lake, UT 84054